

ASSEMBLY INSTRUCTIONS

A2 MOTION DISPLAY BOARD

- 1 Unpack both shipping boxes and check to be sure that all 6 components following are included:
- Display Board
 - Stand
 - Base
 - Power Cord
 - Allen Wrench
 - Keys (2) - *not used for assembly*

- 2 Use a 7/16" or 11 mm socket wrench to reverse-out the 4 screws/washers from bottom of Stand, line-up Base and Stand, then attach with the 4 screws/washers (see FIG. A). Then stand assembly upright.

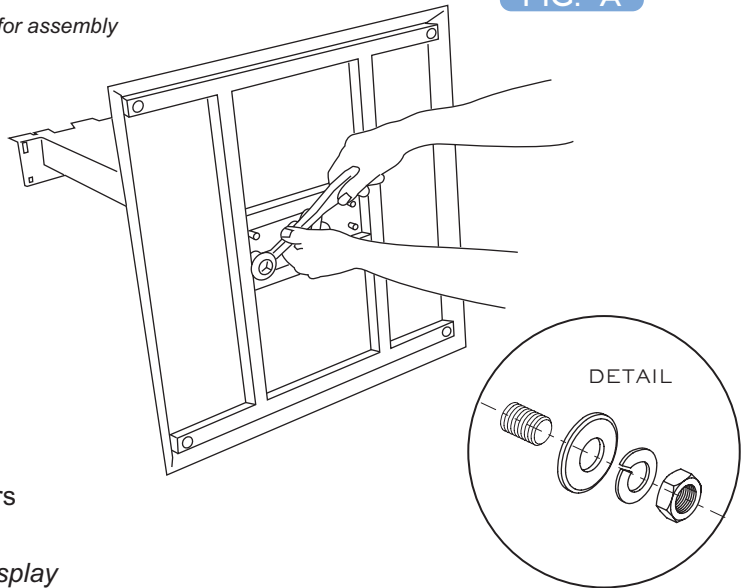

- 3 Use the supplied 5/32" Allen Wrench to reverse-out the 4 screws/washers from bottom of Display, line-up Display on top of Stand, then attach with the 4 screws/washers (see FIG. B).

*** **Note:** *not stable -- be sure to hold the Display in place until 1 screw is fully tightened. ****

- 4 Connect the Power Cord in to the back of the back of the Display, then plug it in to a standard 110-volt power outlet. Then turn the unit on using the switch on the back of the Display.

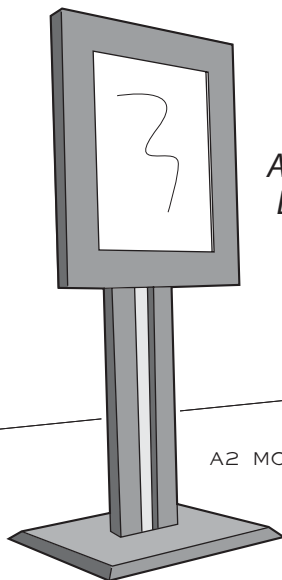
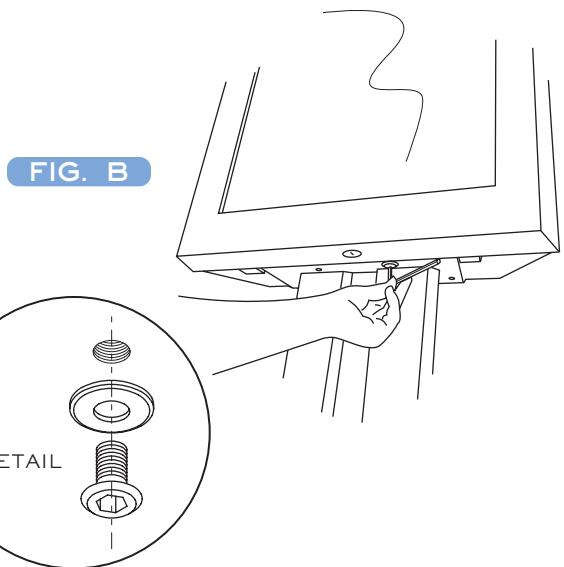

*All New Graphics
Every Few Seconds!*

A2 MOTION DISPLAY BOARD

Distributed By:

QuestCom Incorporated
1255 University Ave, Suite 205
Rochester, New York 14607
585.458.0011 • 458.1564 fax
www.questwebstudio.com

